

Property Security Using a Biometric Based Door Lock System

Onyan AO, and Enalume KO*

Department of Electrical and Electronics Engineering, Federal University of Petroleum Resources, Effurun, Delta State, Nigeria

*Corresponding author: Enalume KO, Department of Electrical and Electronics Engineering, Federal University of Petroleum Resources, Effurun, Delta State, Nigeria, Tel: 08067177302, E-mail: enalume.kingsley@fupre.edu.ng

Citation: Onyan AO, Enalume KO (2018) Property Security Using a Biometric Based Door Lock System. J Biostat Biometric App 3(3): 302

Received Date: June 20, 2018 Accepted Date: August 6, 2018 Published Date: August 9, 2018

Abstract

This paper presents the development and implementation of a Biometric Based Door Lock System that will automatically unlock a door when a registered fingerprint is sensed. The method employed in accomplishing this involves the use of a fingerprint scanner R305 interfaced with ATMEGA 328 Arduino microcontroller to actuate the locking and unlocking process of a door. Once a registered finger print is placed on the sensor, access is granted to the user, the door slides open and it closes after five seconds. During this process, the 16x2 Liquid Crystal Display (LCD) displays the name of the individual with the registered fingerprint. If an unregistered fingerprint is sensed, access is denied. The developed Biometric Based Door Lock System was tested and it functioned in line with the desired objectives.

Keywords: Biometric; Door Lock; Access; Fingerprint; Scanner

Introduction

Security of human life and property is one of the paramount challenges facing individuals, corporate organizations or any nation. The problem of insecurity of properties and intrusion into premises dates back as far as the existence of man. One major means of achieving security within a building is through the door access control. The door access control provides security by limiting unauthorized access and possibly taking record of those that passes through it [1]. Basically, door access control is achieved through locks in doors [2]. During the rise and fall of different civilizations, locksmiths developed tools and equipment used for security purpose [3]. During the medieval period, traditional methods were used for implementing the making of these security tools. As time went on, these tools and equipment became obsolete as people could easily breach the security perimeters set by these security equipment and so people continually sought for more reliable security measures. Heavy urbanization and industrialization around the world deepened the interest of people in building more sophisticated security systems that could combat the challenges of securing valuable properties. During the day, most homeowners will be at work or out of the home running errands. This makes the home an easy target for burglary and significantly reduces the chances that the criminal will get caught. Besides, the traditional door lock uses a key which can easily be opened by an unauthorized person or burglar if he/she has the right key or a duplicate. This will allow burglars to steal the valuables in the homes. Home owners also cannot open the door when they lose the keys to locks as they will need to wait for the technician to come to open the door. Another challenge is that when the key is misplaced or locked away in the house it will even deny the authorized person from gaining access to his property. It leads to calling a technician to fix the problem bringing undue cost on the authorized person [4]. Besides gaining access to a building, lock system can also be used to provide/prevent access to personal belongings and documents both at home in the office. Some of these belongings could be confidential documents, money, expensive jewelries, etc. To militate against these challenges, some security systems have been developed to prevent unauthorized access, such as, the use of smartcards, passcode, voice technology, RFID and biometrics [5-8]. In this work a biometric based door lock system was developed. Biometric involves the science of statistically analyzing biological characteristics. Any technology that automatically recognizes or verifies the identity of an individual using a measurable physical or behavioural characteristic of the person is a biometric system. Some of the conditions for choosing the characteristics are, universality, uniqueness, permanence, collectability, acceptability, performance and circumvention. Different characteristics such as fingerprint, facial features, eye features, etc. can be used by biometrics [9]. This work developed a fingerprint biometric door lock system.

Related Works

Several works on lock system have been done using different methods to grant/deny access. Reviews of some of these systems are as presented. In smart card technology was used to provide the needed security [10]. In this system, a card in reader and a card out reader were installed on the outside and inside of the door respectively to allow for entry and exit of the building. To gain access, a user must insert a valid card into the card reader slot, and then the card reader will decode the information in the card and pass it on to the microcontroller. The microcontroller then decipher the name on the card and compare it to the names in its memory. If it matches, it grants access by triggering the motor driven electromechanical door to slide open or denies access, if it does not match. The major drawback of this system is once an unauthorized user gets hold on the card he can access the property.

In fingerprint scanner was used as the medium of access [11]. Fingerprint enrollment was done for the authorized user. The pattern of the thumb and index finger was scanned and stored in the system. To gain access, the fingerprint of the user must match the pattern of the thumb and index finger. If a wrong fingerprint is detected for three consecutive times, the system automatically generate a passcode which it sends to the mobile phone of the authorized user to alert him of the intrusion. At this point to open the locker, the passcode is entered using the keypad on the device.

Password system was used in [12]. To authenticate the user, a numeric code of four digits is entered and the microcontroller checks to see if it matches with the preset password. If it matches, the locker is opened, if not buzzer is activated and it sounds an alarm.

To further provide security to the password system incorporated a web cam that takes the picture of the unauthorized user and stores it in the system memory after entering the wrong password for three consecutive times [13].

Design Analysis

As shown in Figure 1, the entire system is divided into the following units:

- i. A power supply unit.
- ii. A sensing unit for enrolling and verifying fingerprint information.
- iii. A processing/control unit that processes the fingerprint information and send necessary control information to the display and control unit.
- iv. A displaying unit which shows the type of access and identity of the user.
- v. The actuator/alarm unit which initiates the opening and closing of the door and activates the buzzer in the case of an intruder.

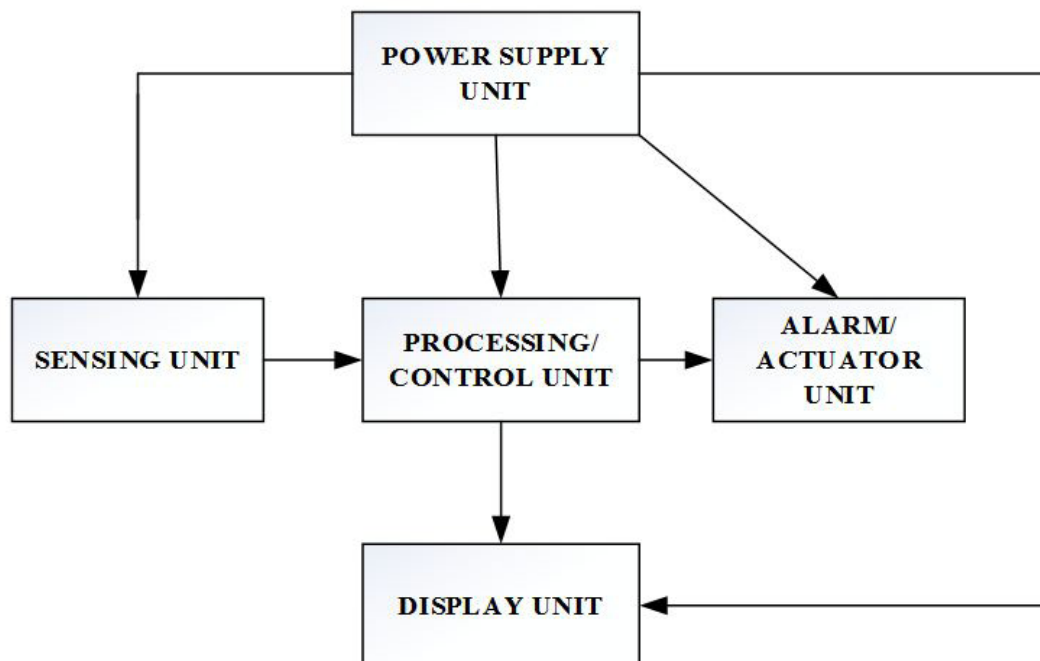

Figure 1: Block diagram of biometric based door lock system

Power Supply Unit

The power supply unit consists of a step down transformer, a bridge rectifier, a filter and LM7805 voltage regulator to supply the 5 VDC needed to power the other units of the system [14,15].

Sensing Unit

The sensing unit consists of a fingerprint scanner R305. The Fingerprint sensor processes fingerprint in two parts; fingerprint enrollment and fingerprint matching. When enrolling, the user needs to place the same finger twice on the scanner. The system will then process the two fingerprint images, generate a template of the finger based on processing results and store the template. When matching, the fingerprint scanner scans the user's finger capturing the fingerprint and then compares it with templates of the fingerprint library in the microcontroller. Then the system will return the matching result as either success or failure.

Processing/Control Unit

The most important part of the processing unit is the Arduino microcontroller shown in Figure 2. It interfaces the finger print sensor with the motor, alarm and LCD display unit. The model used in this work is ATMEGA 328. It has a power jack, a reset button, a total of 20 pins (0-19) in which 6 are analog inputs, a ceramic resonator of frequency 16MHz and a USB connector. The Microcontroller was programmed using C language and the program was compiled using MicroC compiler. The microcontroller processes the pulses received from the finger print sensor by comparing the fingerprint from the scanner with the template stored in its memory. If it matches it will send control signal information to actuate the door lock process and also enable the LCD to display the identity of the authorized person. If it does not match, control signal information is not sent to the actuator unit. Thus, access is denied to the unauthorized person.

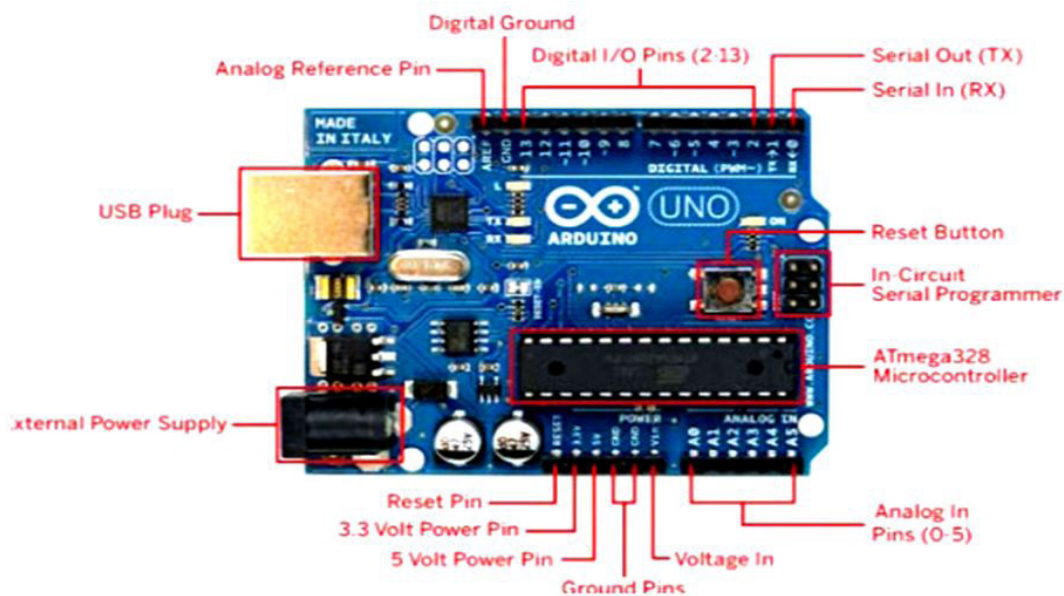

Figure 2: Diagram of Arduino UNO with its parts

Alarm/Actuator Unit

This unit is made up of a D.C motor, a buzzer, relays and other active components such as transistors. The motor rotates a certain number of times either anticlockwise or clockwise to open or close the door once the correct finger print is sensed. Once a correct finger print is sensed, the microcontroller sends control information to the DC motor to turn in the anticlockwise direction to open the door. It is able to accomplish this through a pulley connected to the slide door. The motor has low noise and low vibration and can attain stable speed because of the stable-speed electronic circuit in the motor. The DC motor has two leads and based on the connections will have bi-directional motion. If a positive polarity is applied to one lead and ground to another the motor will rotate in one direction. If the polarity of the connection of the motor is reversed, it will rotate in opposite direction. If both leads are opened or if both leads are grounded, it will not rotate. If positive voltage is applied to both leads then braking will occur. Thus the motor is controlled by the polarity of voltage supplied to the leads.

As shown in Figure 3, two relays are used to switch between the polarities of the motor depending on the signal from the microcontroller. The relays are single pole double through (SPDT) type driven by an NPN bipolar junction transistor. When the collector current (IC) flows towards the "Relay 1", it switches to normally open and "Relay 2" will be closed, thereby allowing current to flow through the motor to ground, causing it to rotate in an anti-clockwise direction, otherwise, if the collector current flows through "Relay 2", the polarity of the motor will change and the motor will rotate in a clockwise direction. By means of the alternating flow of current through the motor, the opening and closing of the door can be achieved. If the wrong fingerprint is placed on the scanner, the buzzer sounds an alarm to alert the authorized user of an intruder.

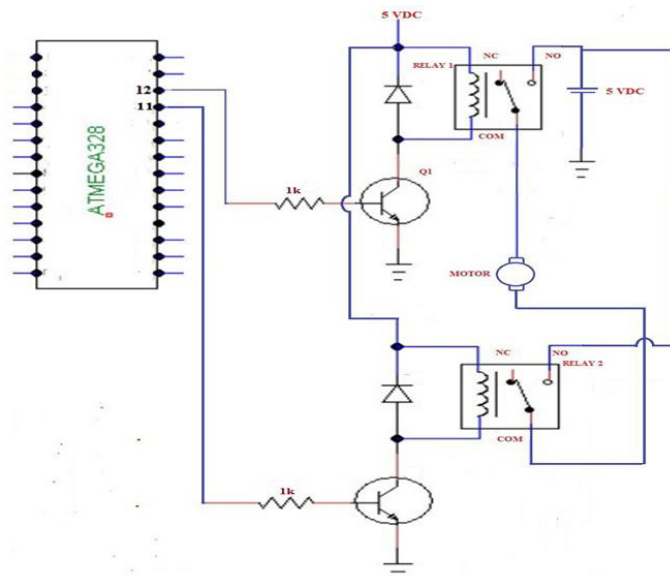

Figure 3: Circuit diagram showing how the motor is controlled using SPDT relay

Display Unit

A 16x2 LCD was used to display the name used in storing the fingerprint information of the authorized user during the registration process and to indicate that access was granted. If access is denied, it will also be shown on the LCD. Figure 4 shows how the LCD is interfaced with the microcontroller. It also displayed the action taken and the name of the authorized person that inserted his finger on the fingerprint scanner.

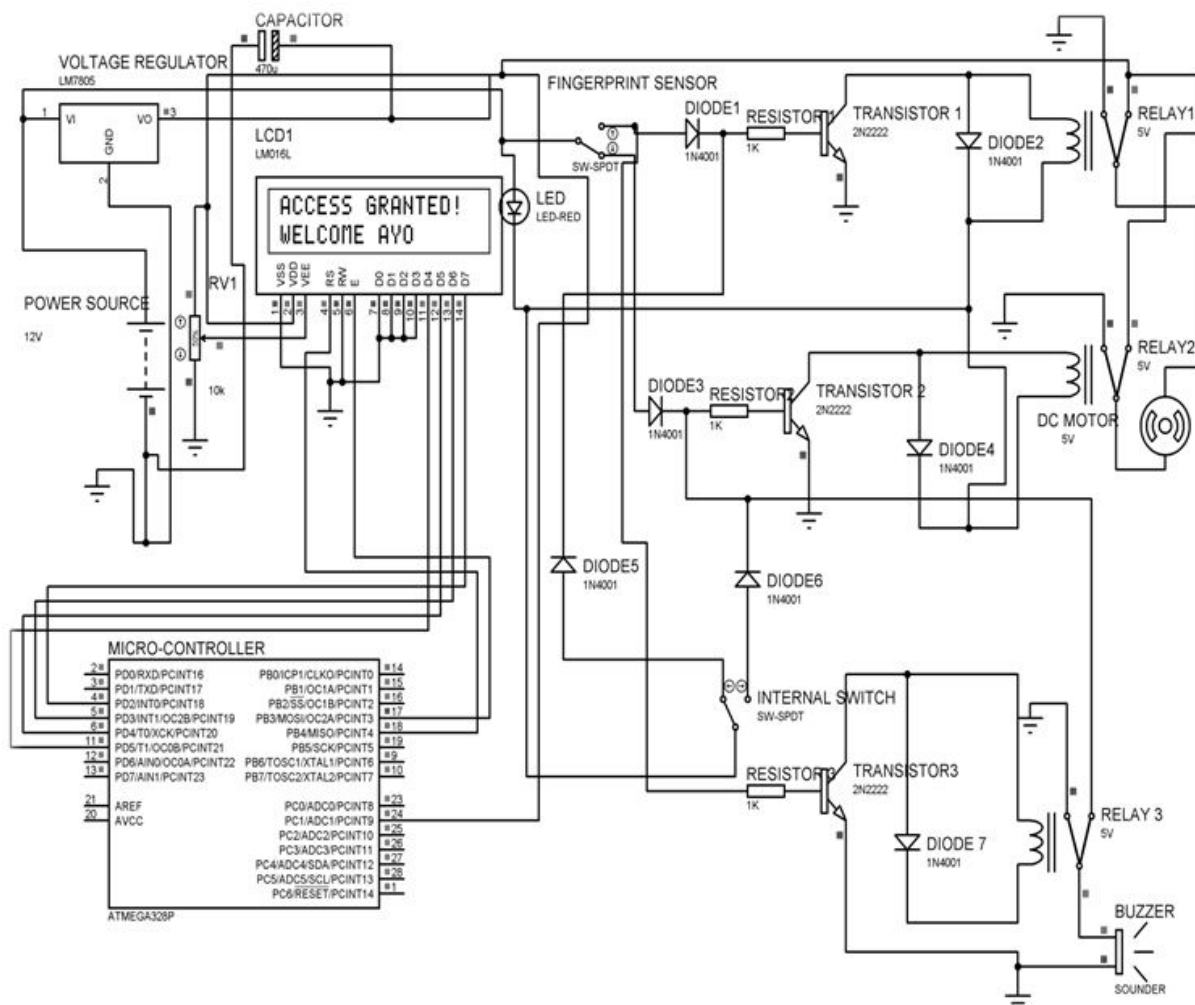

Figure 4: Circuit diagram showing how the LCD works in the system

Mode of Operation

There are two modes of operations which are the registration and authentication process. The process involved in the registration of a fingerprint is described below:

- i. Connect the microcontroller using a USB jack to a computer having Arduino programmer installed in it.
- ii. Upload the enroll code to the Arduino programmer and compile it.
- iii. Click on Serial monitor in the Arduino program. Once the Serial monitor pops up, the fingerprint sensor will blink red continuously.
- iv. Place the required fingerprint on the sensor to register.
- v. Upload the fingerprint sketch (code).
- vi. Repeat step 'iii' and 'iv' to confirm. After the confirmation the red light will remain stable.
- vii. After the following steps have been properly executed, access can be granted to the apartment.

Figure 5 shows the authentication process of the biometric system. The system is designed in such a way that, when an individual places his/her fingerprint on the sensor, the sensor captures the fingerprint and compares it with the registered fingerprint. If a match is found, the door will open for 5 seconds and then closes automatically. To control the direction of a motor, the polarity applied to the motor's leads must be reversed. A simple manual-control approach is to use a SPDT switch. Alternately, a transistor-driven SPDT relay can be used. This circuit uses a complementary pair of transistors both of which are NPN transistor. When 12 V is applied to the input, the upper transistor conducts, allowing current to pass from the positive supply through the relay to the motor and to ground. If a 0 V is applied to the input, the lower transistor conducts, allowing current to pass through the relay to motor from ground into the negative supply terminal.

Also, the LCD displays the name of the individual with that particular fingerprint and indicates that access is granted. If the fingerprint is not recognized, the door will remain closed, the LCD will display access denied and the buzzer will be activated once the finger is placed up to three times on the sensor.

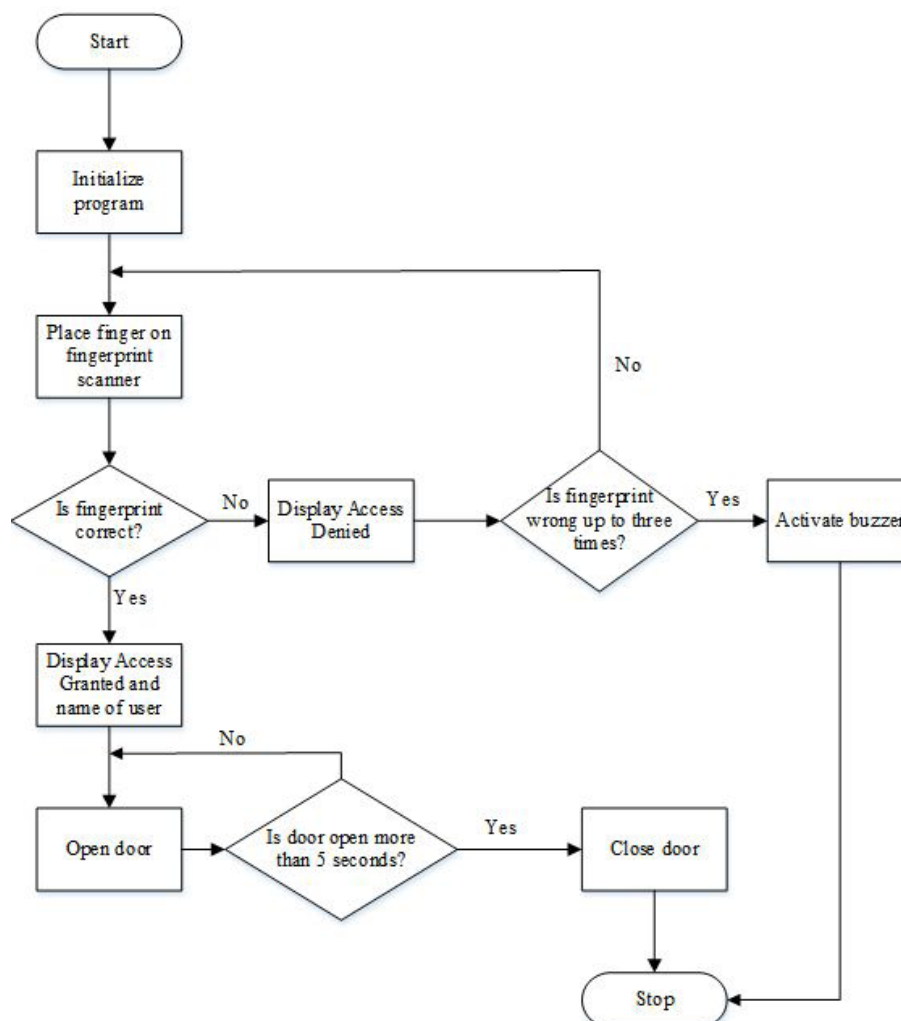

Figure 5: Flowchart of the biometric door lock authentication process

Performance and Evaluation

This was conducted to determine how the system responds to inputs from the sensors to see its performance. Figures 6-9 show the pictures of the implemented work being tested.

Figure 6 shows the initial stage with the door locked with the LCD displaying “INSERT FINGERPRINT ON SENSOR”. When a finger was placed on the fingerprint scanner, and it was recognized, the LCD displayed “ACCESS GRANTED” as shown in Figure 7. Figure 8 shows the system granting access to a registered user by displaying “ACCESS GRANTED” together with the name of the registered user. At the same time, the door slides open when the fingerprint sensor senses the registered fingerprint. The buzzer also makes a sound during this period. Figure 9 shows the system denying access to an unrecognized fingerprint.



Figure 6: Picture of the system at its initial state



Figure 7: Picture showing access granted to a recognized fingerprint

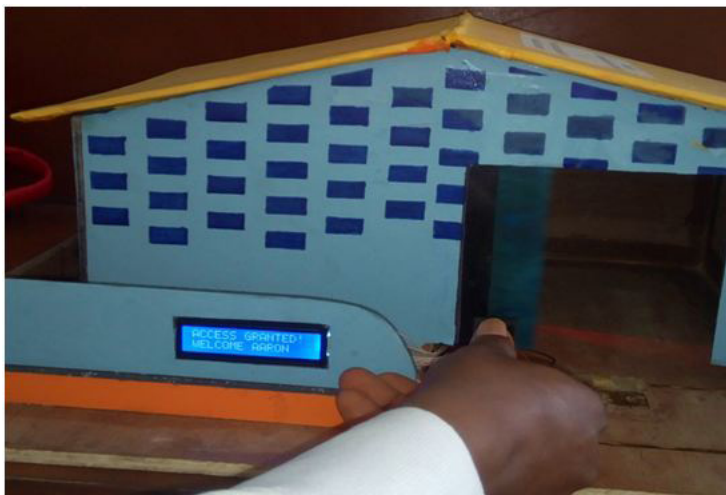

Figure 8: Picture showing door sliding open



Figure 9: Picture showing access denied to an unrecognized fingerprint

Conclusion

The objectives of the developed Biometric Based Door Lock System were achieved as evidenced from the tests performed. This system takes care of the limitations inherent in the available mechanical door lock systems. The system is reliable in view of the fact that fingerprints are unique to each individual and fingerprint is always available for use unlike the mechanical key that is sometimes forgotten or even misplaced.

References

1. Winda WO, Mohammed S (2007) Intelligent Voice-Based Door Access Control System Using Adaptive-Network-Based Fuzzy Inference Systems for Building Security. *J Comp Sci* 3: 274-80.
2. Bellis M (1972) *The History of Locks*, Dotdash HQ, New York, USA.
3. Schlage (2016) *Schlages's History of Locks*, Russia.
4. Abraham DG, Dolan GM, Double GP, Stevens JV (1991) Transaction Security System. *IBM System J* 30: 206-29.
5. Reid J, Looi M (2000) Making Sense of Smart Card Security Certifications. 4th Working Conference on Smart Card Research and Advanced Applications, Bristol, UK.
6. Omijeh BO, Ajabuego GO (2013) Design Analysis of a Security Lock System Using Pass-Code and Smart-Card. *IOSR J Elect Comm Eng* 4: 64-72.
7. Odia A (2007) Design and Construction of a Security Lock System Using Pass-Code, Smart Card and Voice Technology.
8. Raghu RG, Subhramanya SG (2013) Locker Opening and Closing System Using RFID, Fingerprint, Password and GSM. *Int J Emerg Trend Technol Comp Sci* 2: 142-5.
9. Zhang DG (2000) *Automated Biometrics*. Klumer Academic Publishers, New York, USA.
10. Oke AO, Olaniyi OM, Arulogun OT, Olaniyan OM (2009) Development of a Microcontroller-Controlled Security Door System. *Pacific J Sci Technol* 10: 398-403.
11. Cortez CD, Badwal JS, Hipolito JR, Astillero DJC, Cruz MSD, et al. (2016) Development of Microcontroller-Based Biometric Locker System with Short Message Service. *Lecture Note Soft Eng* 4: 103-6.
12. Annie OP, Rahul AP, Pranav V, Ponni S, Renjith N (2014) Design and Implementation of a Digital Code Lock. *Int J Adv Res Elect Electr Instrument Eng* 3: 7604-7.
13. Hamsa FT (2015) Safety and Security of the Personal Belongings Using Microcontroller. *Diyala J Eng Sci* 8: 28-37.
14. Epemu AM, Enalume KO (2017) An Efficient Phase Fault Monitoring System for Distribution Transformers. *Int J Adv Res Eng Manag* 3: 62-8.
15. Enalume KO, Okhueigbe E (2017) Design and Construction of a Mobile Phone Based Home and Office Appliances Remote Switching System. *Am J Embed Sys App* 5: 1-6.

Submit your next manuscript to Annex Publishers and benefit from:

- ▶ Easy online submission process
- ▶ Rapid peer review process
- ▶ Online article availability soon after acceptance for Publication
- ▶ Open access: articles available free online
- ▶ More accessibility of the articles to the readers/researchers within the field
- ▶ Better discount on subsequent article submission

Submit your manuscript at
<http://www.annexpublishers.com/paper-submission.php>